

Urban Brick

We replaced a deteriorating, rusted fluorescent fitting that was built into a brick wall. The fixed architecture meant standard fittings wouldn't work, so we designed a solution specifically to fit the existing structure.



Features

- Tailored to fit directly into the existing Brick wall architecture
- Energy-efficient solution
- Tamper-Proof
- Weatherproof (IP65 Rated)
- Improved Aesthetics:
- Reduced energy consumption

Applications

-  Custodial
-  Car Park
-  Vandal Resistant
-  External

The Problem

The client's traditional fluorescent fittings were outdated, rusted, and in a state of failure. The fittings were too damaged and rusted to accommodate a retrofit solution, necessitating a tailor-made-to-fit solution.

The Solution

We designed, manufactured, and supplied the perfect fitting for the brick wall. Our solution was designed to be IP65, waterproof, and tamper-proof to withstand the conditions of its environment. The result was a made-to-fit unique fitting that met the customer's requirements and provided significant energy savings.

Dimensions

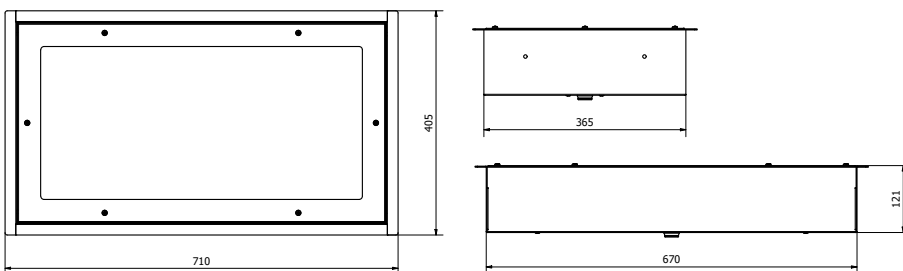

Urban Brick



Design

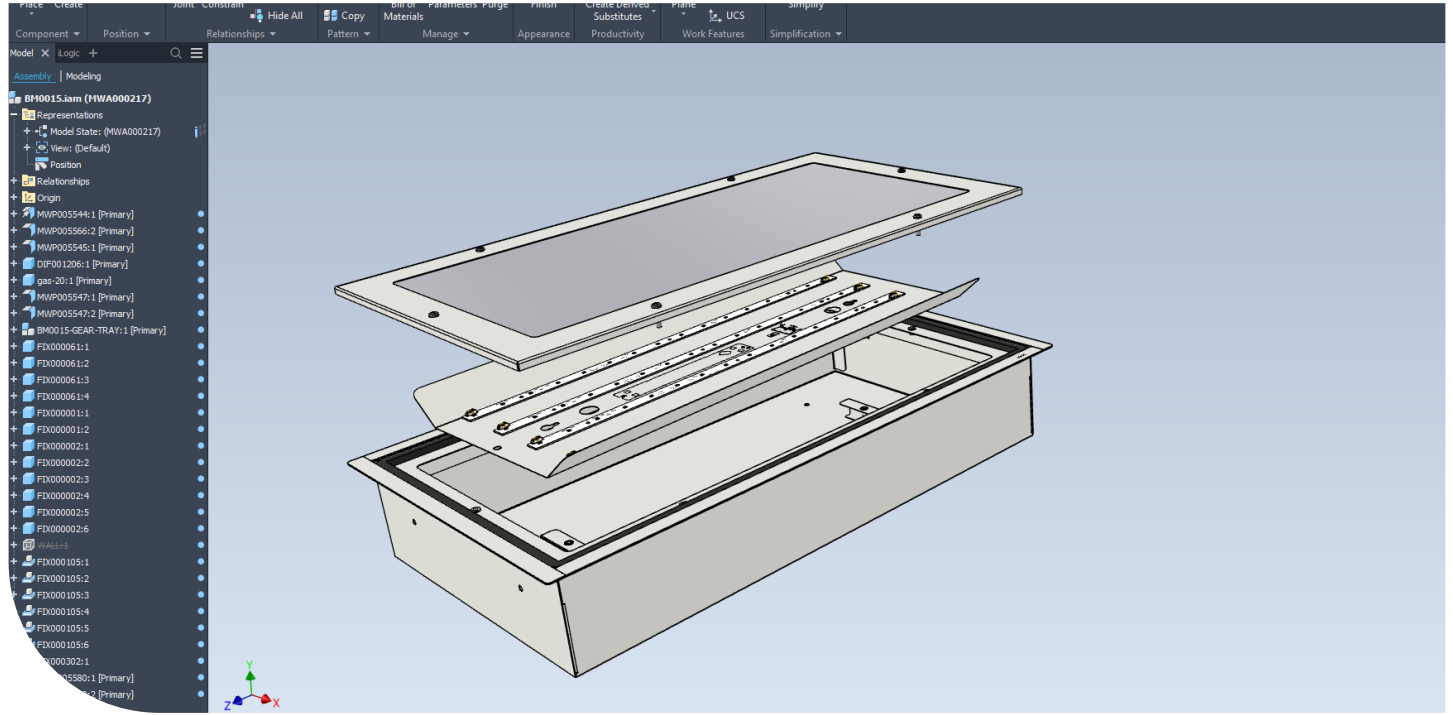

Finished Product

