

Pit Eco

The Pit Eco is an IP69K-sealed luminaire for rail and heavy industry environments. The end caps are fabricated from 316 stainless steel. The housing is polycarbonate or acrylic depending on agent exposure, with an IK10 rating and features flexible mounting/wiring options.



Features

- Opal or clear Diffuser options
- PC or PMMA options
- 316L Stainless Steel End caps
- 316L Stainless Steel bracketry
- Flexible mounting options
- Through wire versions available
- Cable options available
- Integral EM options available
- Black 2M PVC Cable standard
- UV Stabilised material
- 22K, 27K, 3K, 4K, 5K, 65K LED Options

Applications

- Industry
- External
- Food Processing
- Corrosive Resistant
- Car Park
- Marine Environments

Accessories

- SU** Suspension Kit (2M)
- FLX** Flex Options

Photometric

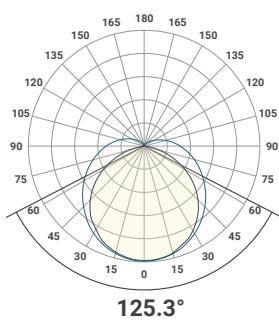

Dimensions



Pit Eco

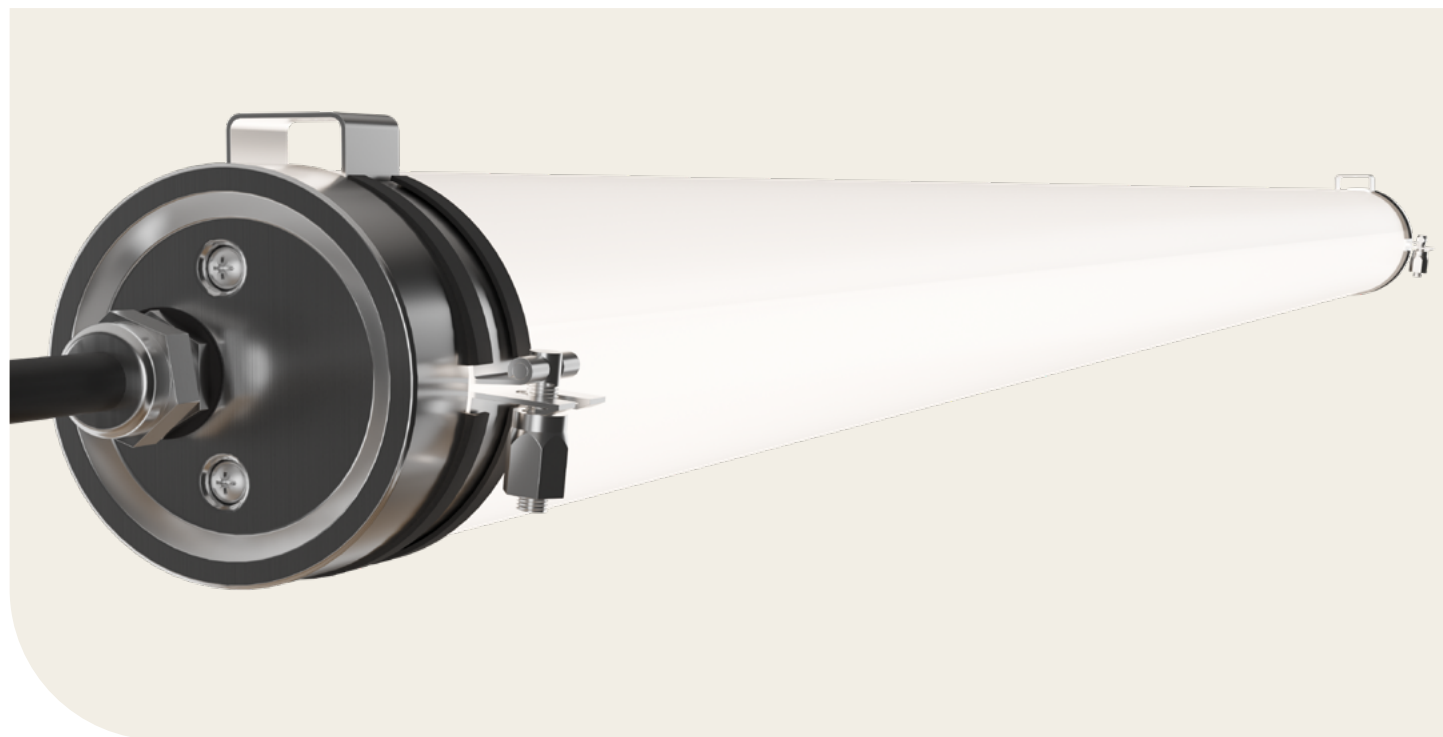

Technical Details

Part No.	Description	Power (W)	Luminaire Lumens	LI/cW
PEC-60-15-4K-FRPC	PIT ECO 5ft Frosted Polycarbonate	60	7200	120.0
PEC-60-15-4K-FRPM	PIT ECO 5ft Frosted PMMA	60	7200	120.0
PEC-60-15-4K-CLPM	PIT ECO 5ft Clear PMMA	60	8400	140.0

Body Material	Diffuser Material	Housing Colour	Mounting Type	CCT Offering	CRI	SDCM	UGR Rating	Dimmable	Dimming Method
Polycarbonate Acrylic	Polycarbonate Acrylic	Clear Opal	Surface Suspended	22K, 27K, 3K, 4K, 5K, 65K	80+	3 step Macadam Ellipse	N/A	Available	SwitchDIM/DALI

IP Rating	IK Rating	Operating Temperature (°C)	L/B value ^{*A}	Terminal Information	Warranty	Weight (kg)
IP69K	IK10	-20° + 40°	60K+ L90/B10	2M Preflex	5 Year warranty 1 year parts and Labour Inclusive	5

^{*A}: L/B value based on T_a25°C operating temperature, standard operation of luminaire within stated parameters. For specific detail please contact info@powerlitefitz.co.uk

Please contact info@powerlitefitz.co.uk for the Inrush current (A) & No.Per 10A breaker.